

# Instrucciones de instalación

Installation Instructions

## Mueble superior cocina Zafiro 180 x 60 cm con módulo campana / Mueble para cocina

*Upper cabinet Zafiro 70.8" x 21.6" with hood module / Kitchen cabinet*



¡Importante!

Important!

Antes de empezar a ensamblar el mueble, lea detenidamente las instrucciones. Pre-ensamble el mueble sobre su caja, para no rayarlos. Si falta una parte o piensa que esta defectuosa no devuelva el mueble al almacén; le agradecemos llamar al Firplak **tel: 4441771 (opción: 2)** o comuníquese con su asesor principal, también nos pueden escribir a **servicioalcliente@firplak.com** o al **Whatsapp** **+57 316-481-2857**

*Before starting to assemble the furniture, carefully read the instructions. Pre-assemble the furniture on its box to avoid scratching it. If a part is missing or you think it's defective, please do not return the furniture to the store. We appreciate you calling Firplak at **tel: 4441771 (option: 2)** or contacting your main advisor. You can also reach us by email at **servicioalcliente@firplak.com** or via **WhatsApp** at **+57 316-481-2857**.*



### Recomendaciones previas

*Previous recommendations*



**Si las paredes donde va a ubicar el mueble son en drywall, debe adquirir chazos y tornillos especiales para su instalación.**

*If the walls where you are locating the cabinet are in drywall, you must purchase special ramplug and screws for installation.*



**No golpee ni martille todo el mueble, sólo donde se le indica.**

*Do not strike or hammer all the cabinet, only where directed.*



**No pinte ni barnice el mueble.**

*Do not paint or varnish the cabinet.*



**No arrastre ni se suba al mueble, si necesita moverlo por favor levántelo.**

*Do not drag or stand on the cabinet, if you need to move it please lift up.*



**Lea detenidamente y siga en orden consecutivo las instrucciones de armado.**

*Read carefully and follow in sequence the assembly instructions.*



**No expongas el mueble a la intemperie, ni al calor.**

*Do not expose the cabinet to the outdoors or the heat.*

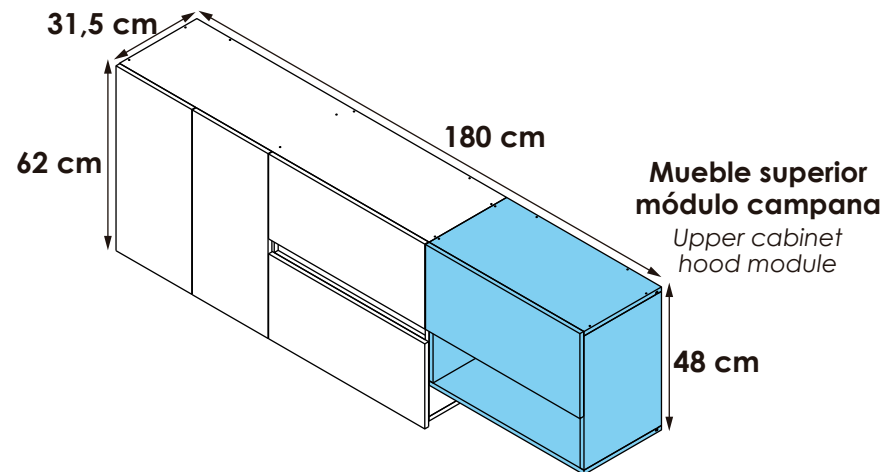

### Sello de calidad / Quality seal

**Por favor no deseche el instructivo del mueble, este le servirá para cualquier reclamo con respecto a la garantía del mismo.**

*Please do not discard the cabinet's instructions, it will serve you for any claim regarding its warranty.*





## Identificación de las partes Parts identification

## Herramientas requeridas / Tools required

\* No incluido.  
Not included.

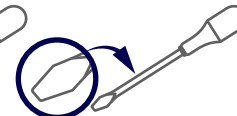
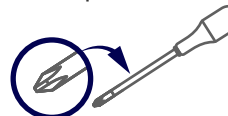
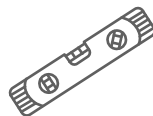

**A** Mueble locero y mueble para almacenamiento.  
Dish cabinet and storage cabinet.

**B** Mueble para campana.  
Hood cabinet.

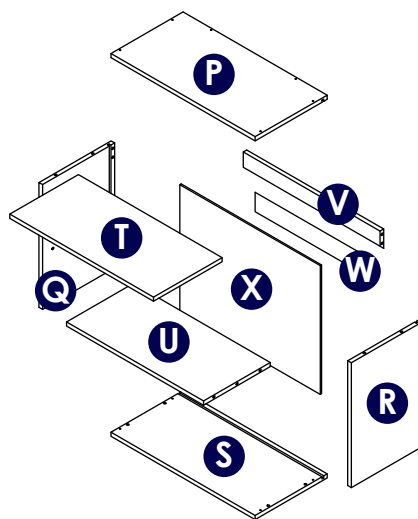
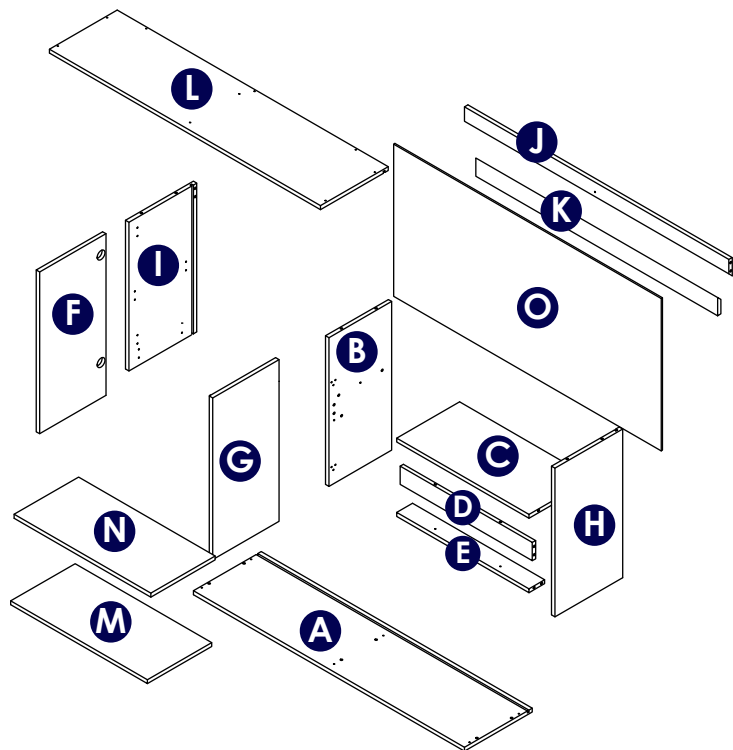

### Tabla de piezas Parts Chart

Pieza / Part	Cantidad / Total	Pieza / Part	Cantidad / Total
A	1	N	1
B	1	O	1
C	1	P	1
D	1	Q	1
E	1	R	1
F	1	S	1
G	1	T	1
H	1	U	1
I	1	V	1
J	1	W	1
K	1	X	1
L	1		
M	1		
		Cantidad Total	Desde hasta
		24	A W

### C Identificación de herrajes Hardware identification



Chazos 2"  
Ramplug 2"



Tornillos chazo 2"  
Ramplug screws 2"



Pernos Minifix  
Spreading bolt



Moneda Minifix  
Minifix cams

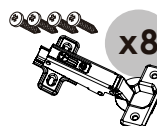

Bisagras parche cierre lento 35mm  
35mm Soft close patch hinges



Bisagras semi parche cierre lento 35mm  
35 mm Soft close half overlay hinges

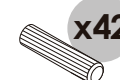

Tarugos  
Wooden pins



Tornillos ensamble 2"  
Assembly screws 2"



Tornillos 5/8  
5/8 screws



Brazo neumático mini liviano  
Mini lightweight pneumatic arm

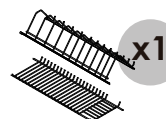

Platero y vajillero 56 cm  
56 cm Dish Rack and Plate Holder



Soporte Locero  
Dish rack Support.



Tenga precaución al abrir la bolsa de herrajes de no perder ningún elemento. Compruebe si el contenido de las piezas es el correcto.  
Be carefull opening the screw bag so you do not lose any. Chek if the number of screws is right.

**D** Recomendaciones de ensambles.  
*Assembly recommendations*

**Instalación de minifix y pernos de minifix**  
*Installing the minifix cams and spreading minifix*

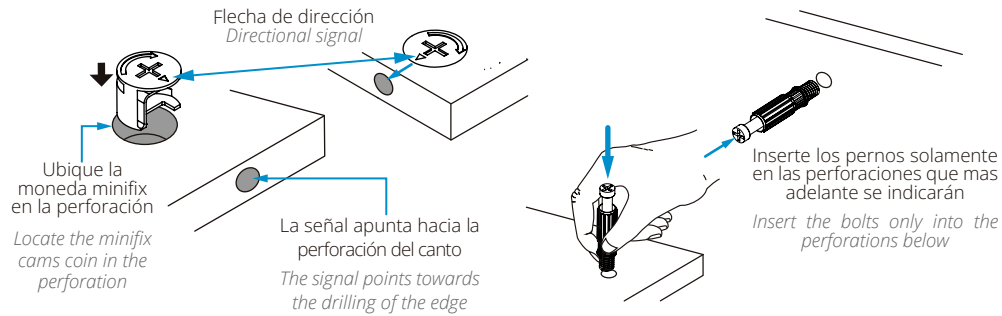

**Ajustes de partes**  
*Parts adjustments*

¿Cuánto debe girar una tuerca?  
*How much should a screw turn?*

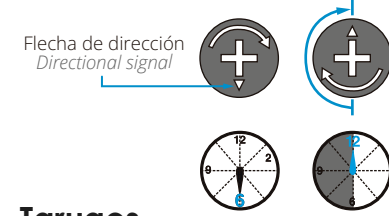

**Tarugos**  
*Wooden pins*

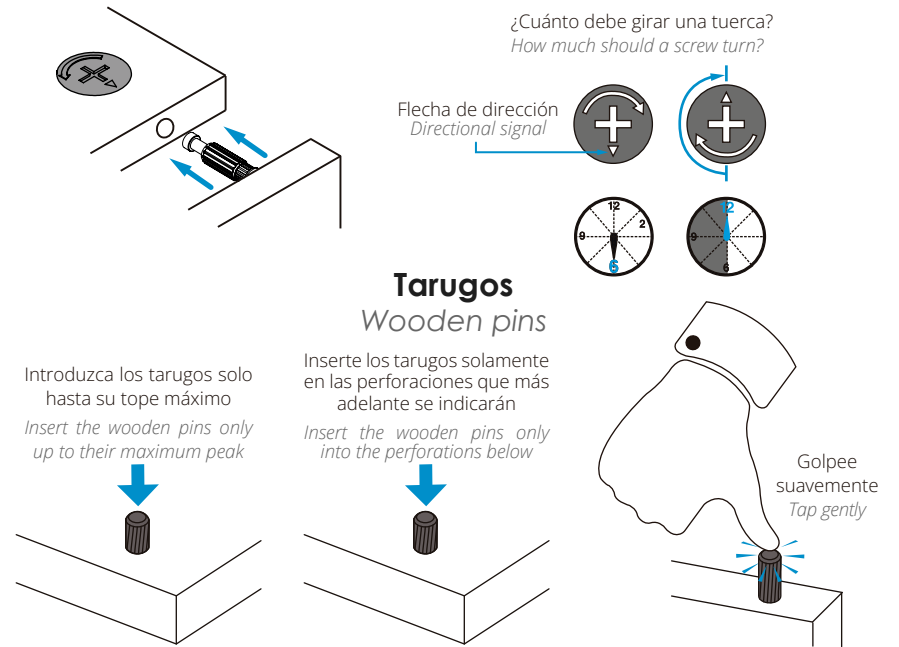

**Preparación de las partes**  
*Preparation of the parts*

✦ Se recomienda armar el mueble sobre la caja o una superficie lisa para no rayarlo.  
*It is recommended to assemble the product top of the box or on a flat surface to not scratch it.*

**Herramientas**  
*Tools*



**Herrajes**  
*Fittings*

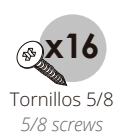
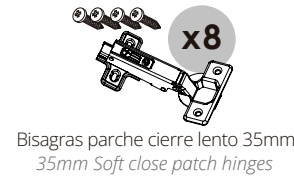
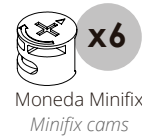

**A** Pre ensamble mueble locero  
*Pre-assembly dish cabinet*

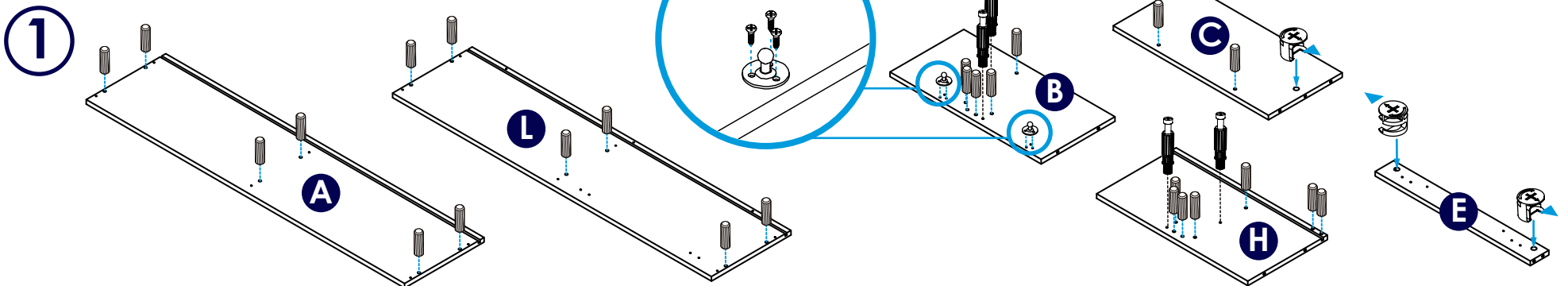

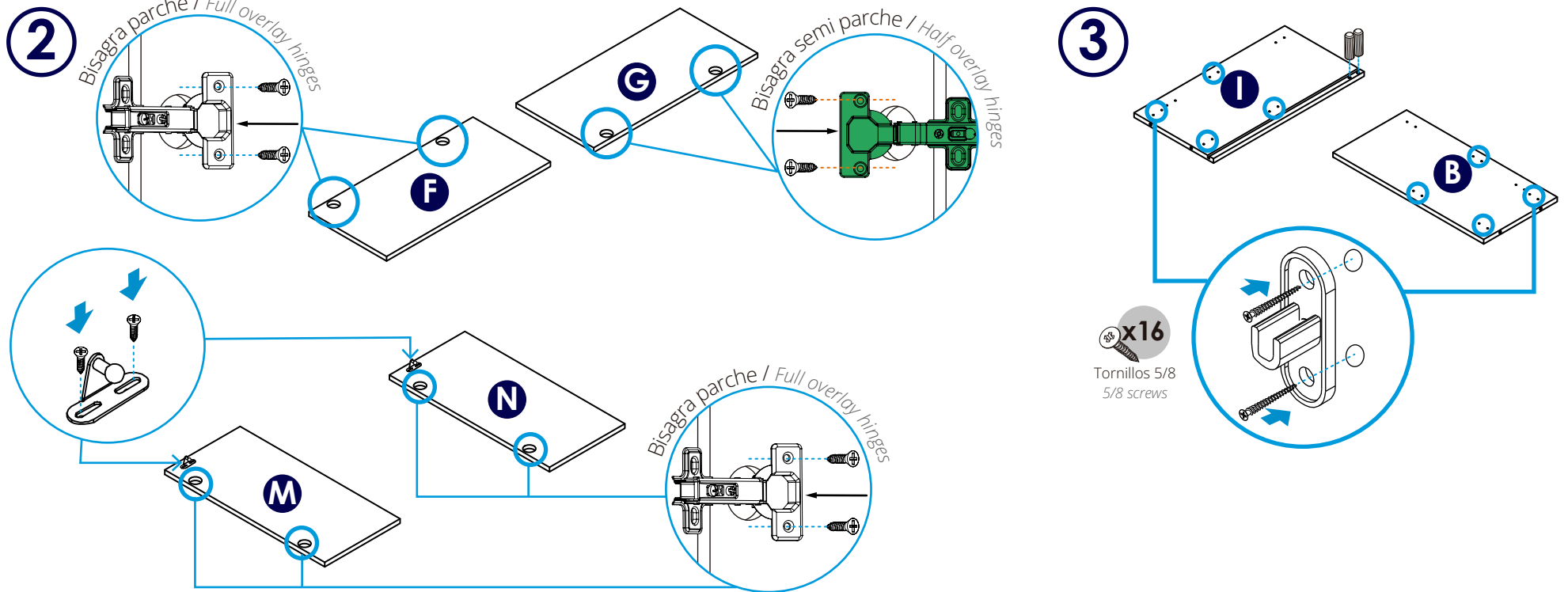

**B** Pre ensamble mueble campana  
Pre-assemble hood cabinet

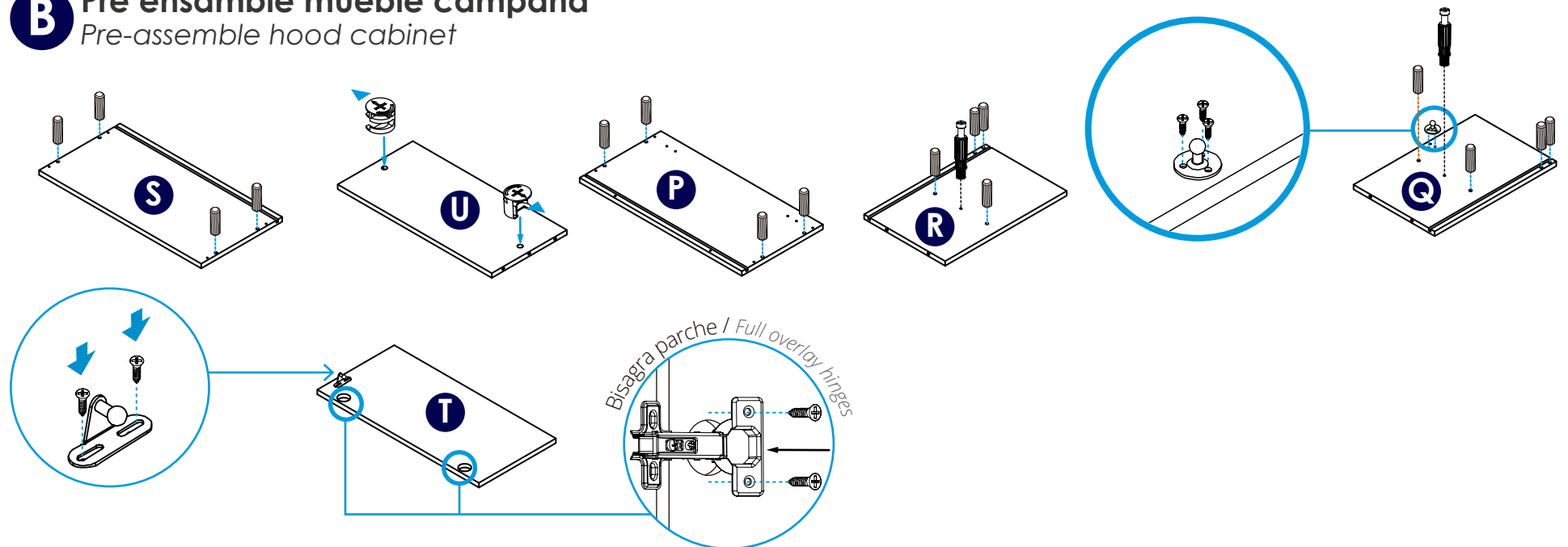



## Ensamble de las partes Assembly of the parts

\* Se recomienda armar el mueble sobre la caja o una superficie lisa para no rayarlo.  
Is recommended to assemble the product top of the box or on a flat surface to not scratch it.

### Herramientas Tools



### Herrajes Fittings



**¡Importante!**

Important!

- De un correcto armado de los muebles depende su buen funcionamiento.
- A medida que vaya encajando las piezas, ajuste con el destornillador.
- A proper assembly of the furniture guarantees the performance of the hinges.
- As the pieces fit together, adjust with the screwdriver.

## A Ensamble mueble locero Assemble dish cabinet

1

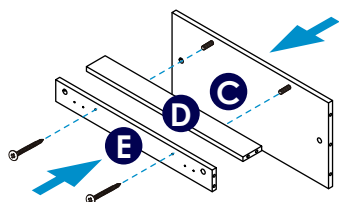

x2

Tornillos ensamble 2"  
Assembly screws 2"

2

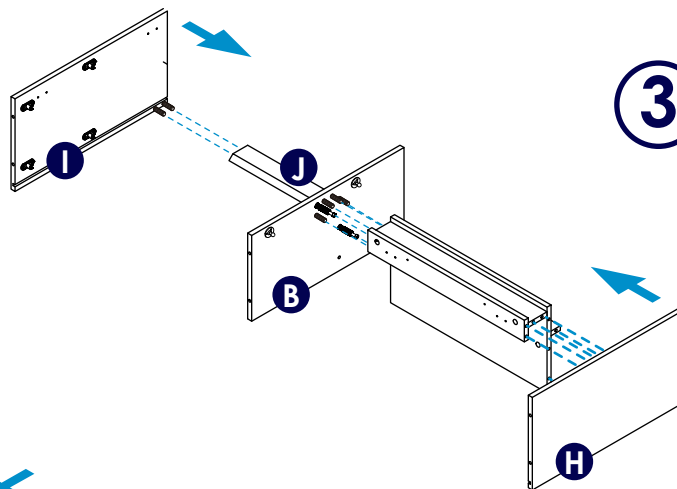

3

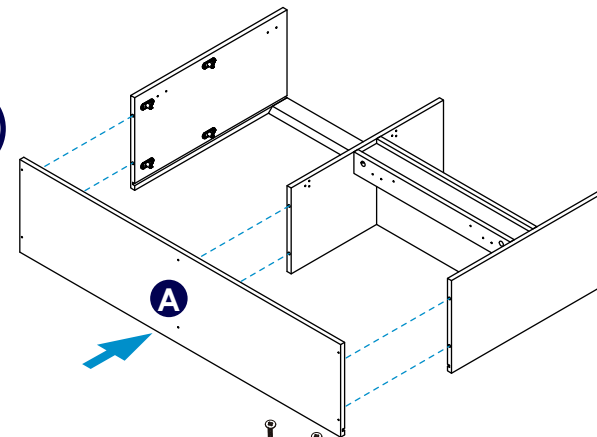

4

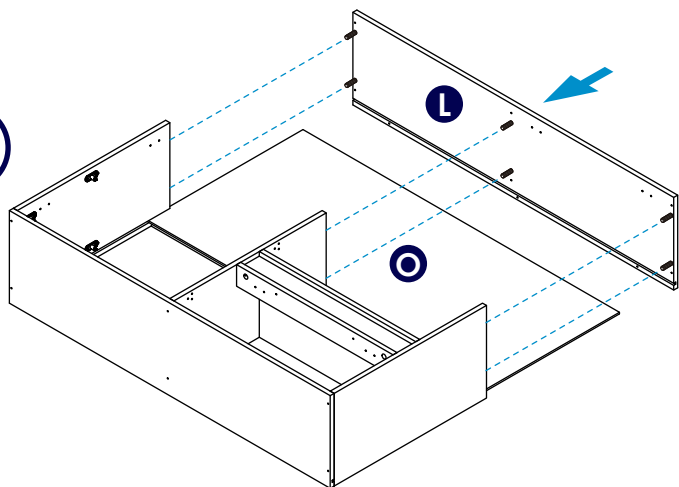

5

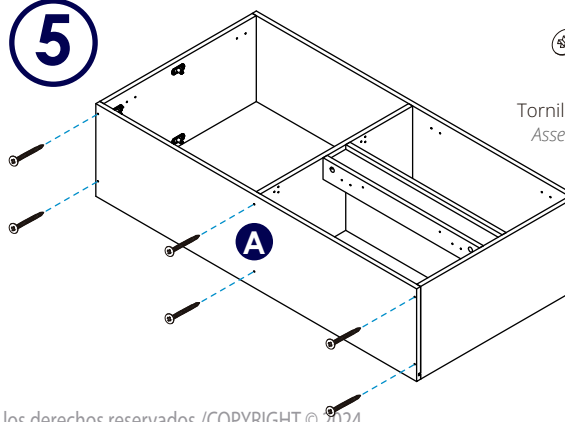

x15

Tornillos ensamble 2"  
Assembly screws 2"

Gira el mueble  
Turn the cabinet

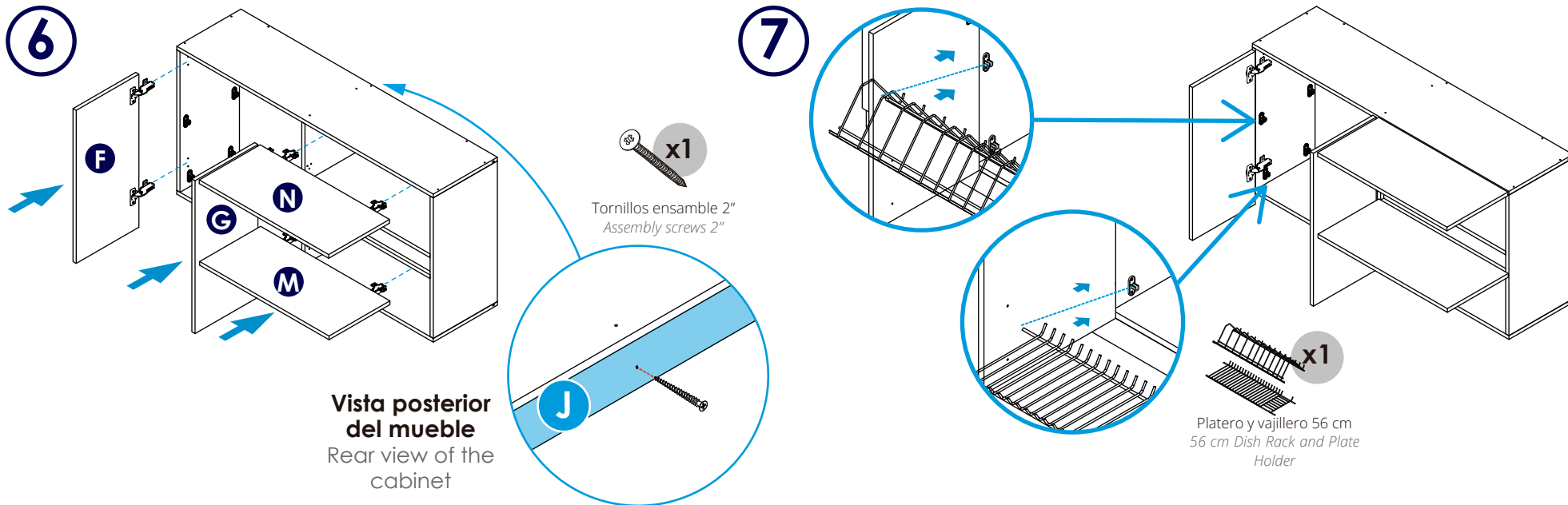

**Vista posterior del mueble**  
Rear view of the cabinet

**6** Montaje de brazos neumáticos **x2**  
Lid support mounting

**Paso 1:** remueva el seguro en ambos extremos.

**Step 1:** remove the lock on both ends.

**Paso 2:** inserte el brazo en los engranches previamente instalados como se muestra en la figura.

**Step 2:** insert the lid support in the hitches previously installed as shown in figure.

**Paso 3:** una vez instalado el brazo inserte los seguros de nuevo.

**Step 3:** once you've installed the lid support insert back the lock.

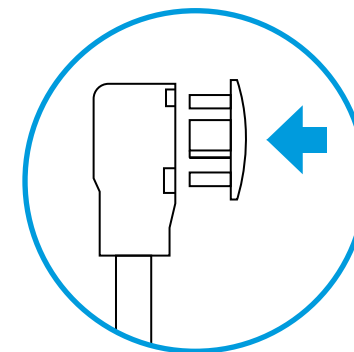
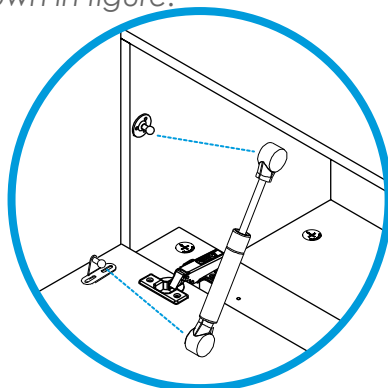
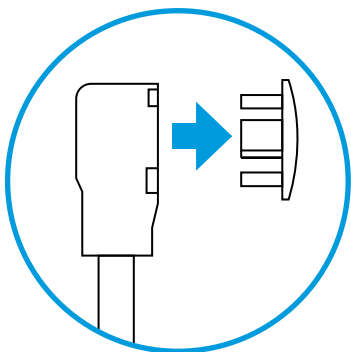

## B Ensamble mueble campana

Assemble hood cabinet

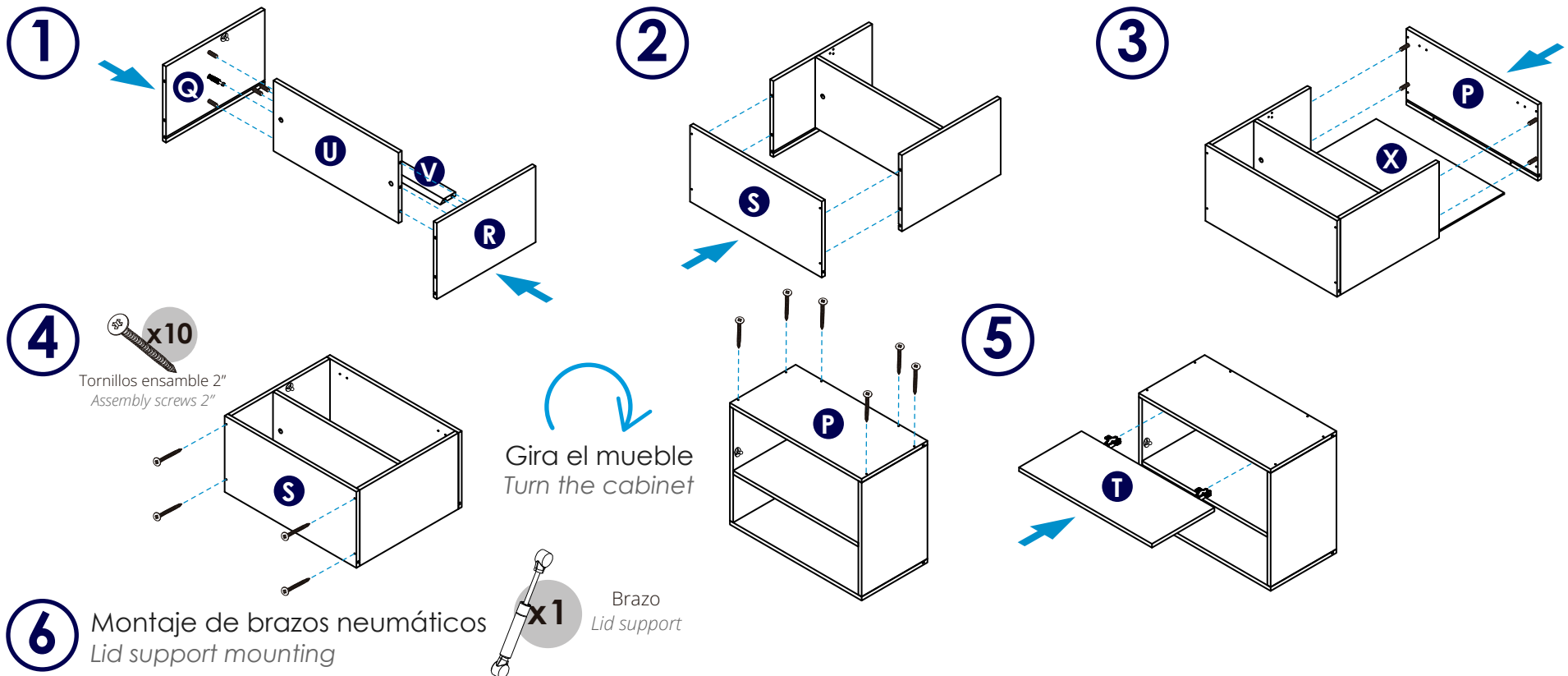

**Paso 1:** remueva el seguro en ambos extremos.

**Step 1:** remove the lock on both ends.

**Paso 2:** inserte el brazo en los engranches previamente instalados como se muestra en la figura.

**Step 2:** insert the lid support in the hitches previously installed as shown in figure.

**Paso 3:** una vez instalado el brazo inserte los seguros de nuevo.

**Step 3:** once you've installed the lid support insert back the lock.

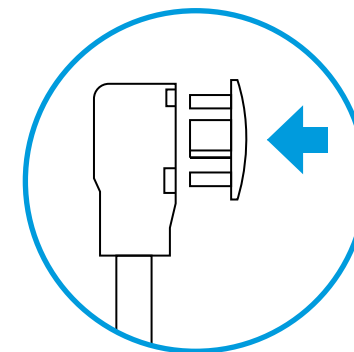
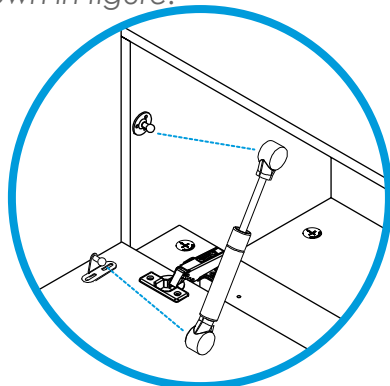
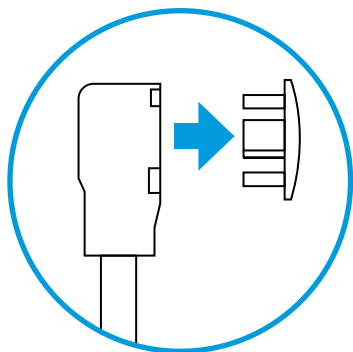

**\* Muebles armados completamente**  
*Fully assembled cabinets*

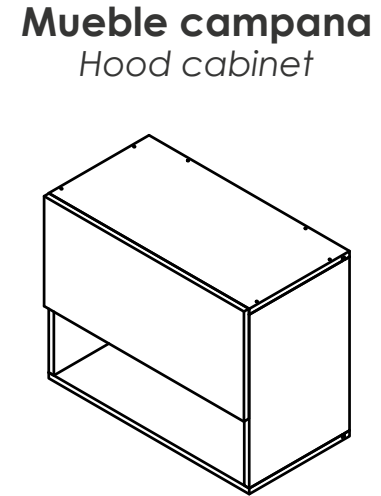
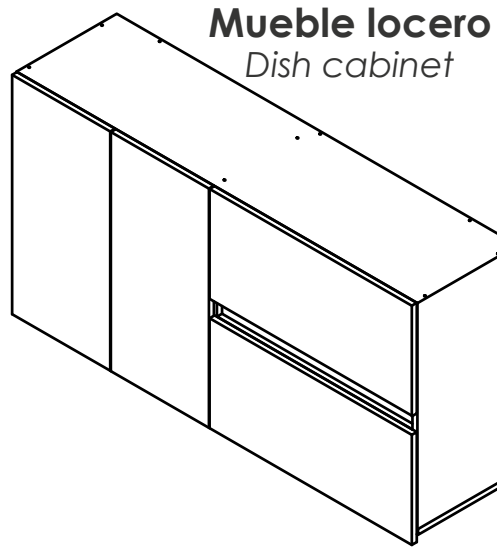

## **C** Montaje del mueble a pared *Wall-mounting cabinet*

**Herramientas**  
*Tools*



**Herrajes**  
*Fittings*



## **Instalación anclaje con cuña** *Wall wedge installation*

**1** Identifique la posición correcta del anclaje con cuña, para que éste pueda ser instalado de manera adecuada en la pared.  
*Identify the correct position of the wall wedge, so that it can be properly installed on the wall.*

Posición correcta  
*Correct position*

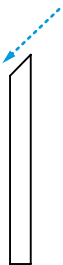

Posición correcta  
*Correct position*

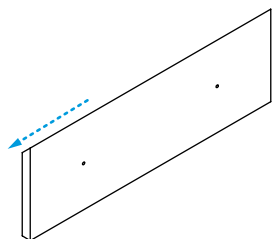

Posiciones incorrectas  
*Wrong positions*

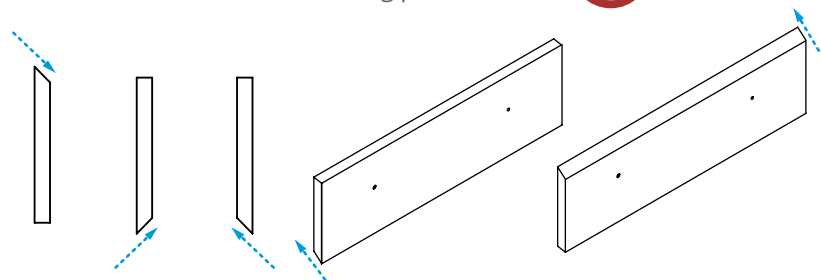

- 2** Mida 1,90 m (medida sugerida) desde el piso hacia arriba, marque el punto final e instale allí los anclajes con cuña con la ayuda de una regla niveladora.

*Measure 74.8" (suggested measurement) from the floor up, mark the end point and install the wall wedge there using a leveling ruler.*

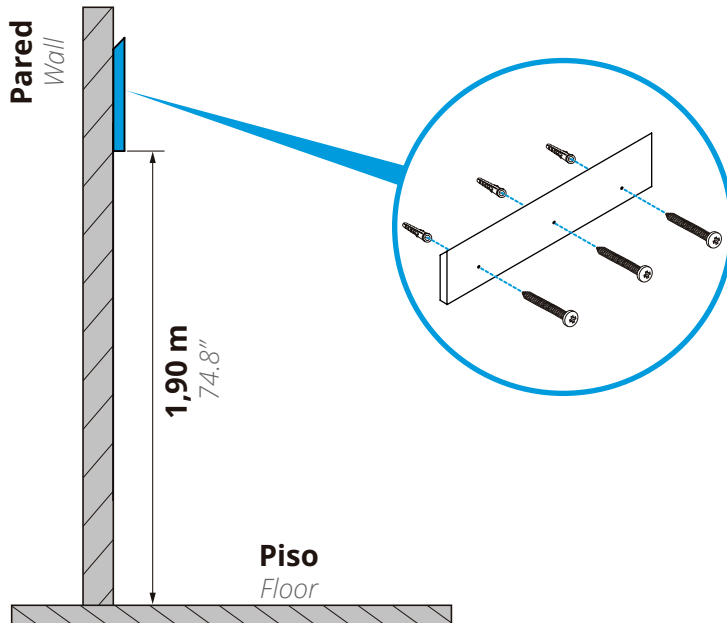

**¡Importante!**

*Important!*

Tenga en cuenta que las paredes deben ser sólidas, de cemento / ladrillo. Si va a instalar el mueble sobre paredes de Drywall (paredes secas), debe utilizar chazos y tornillo de expansión metálico especial para drywall.

*Note that the walls must be solid, cement / brick. In case of drywall installation, change the ramplug for a drywall metallic Spring Toggle.*

- 3** Para fijar el mueble: Perfore la pared a la altura de los agujeros ubicados en las piezas S y T del mueble con ayuda de una broca para pared (tungsteno) 3/8", luego introduzca los chazos plásticos y fije las piezas S y T a la pared con la ayuda de los tornillos chazos; para finalizar descargue los muebles como se muestra en la siguiente imagen.

*To secure the cabinet: Drill the wall at the height of the holes located in the pieces S and T of the cabinet using a 3/8" wall drill (tungsten), then insert the plastic shafts and fix the pieces S and T to the wall with the help of the chazos screws; Finally, download the furniture as shown in the following image.*

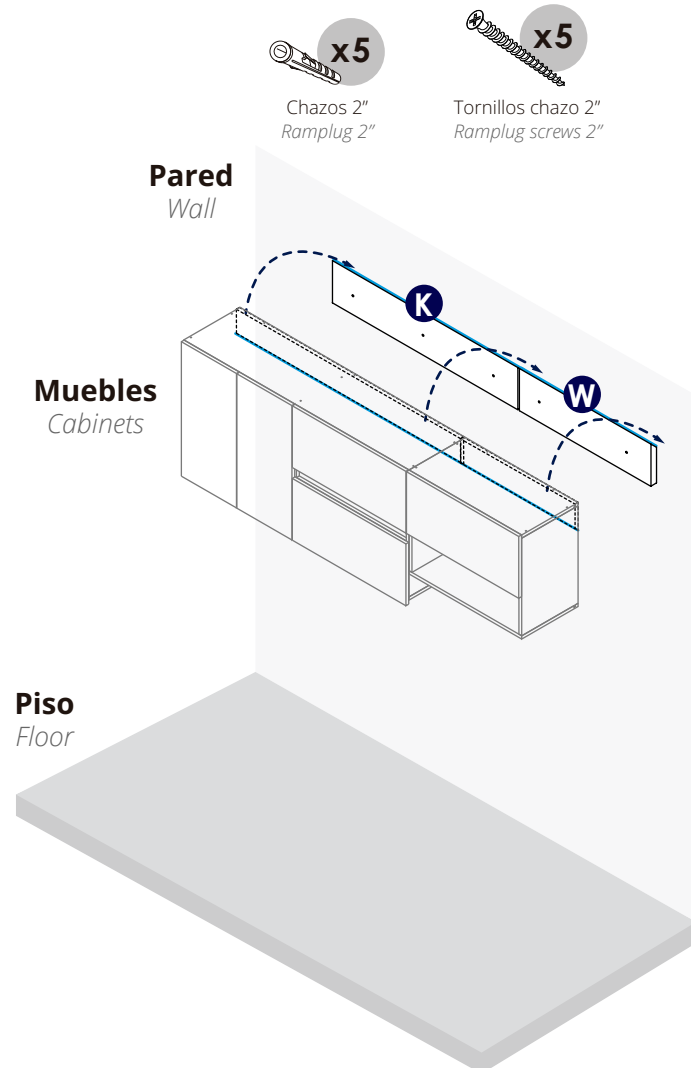

## 4 Nivelar las puertas. Level the doors

**A. Nivelar:** Para nivelar las puertas cuadrándolas al nivel deseado, afloje el tornillo de la bisagra, como lo muestra el detalle. Cuando esté en el lugar indicado, asegure los tornillos bisagra.

**A. Level:** To level the doors, to meet the desired level, loosen the hinge screw, as shown in detail. When in the right place, secure the hinge screws.

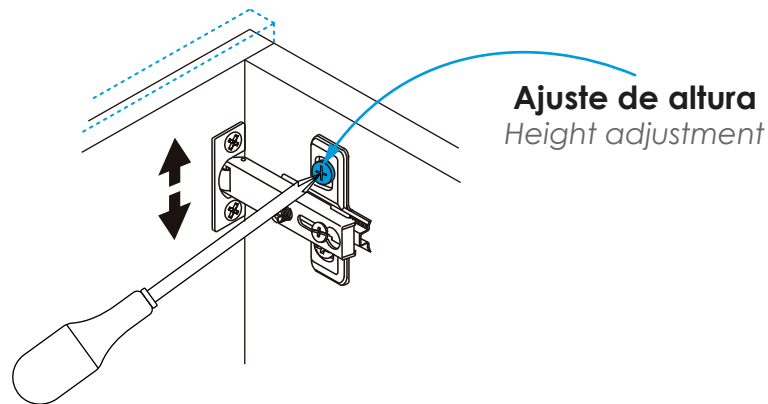

**D. Ajuste lateral:** le permite llevar las puertas hacia la derecha o la izquierda, nivelándola con los laterales aflojando o apretando el tornillo de la bisagra como lo muestra el detalle.

**D. Side adjustment:** Allows you to move the doors to the right or left, leveling with the sides loosening or tightening the hinge screw as shown by the detail.

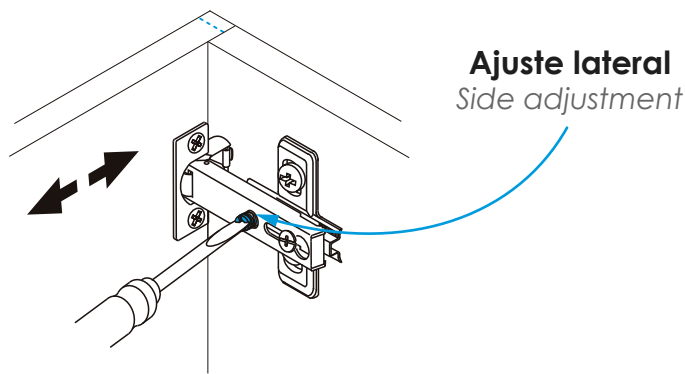

**B. Ajuste de profundidad:** le permite llevar las puertas hacia dentro o hacia afuera, aflojando el tornillo de la bisagra, como lo muestra el detalle.

**B. Depth adjustment:** allows you to move the doors in or out, loosening the hinge screw as shown in detail.

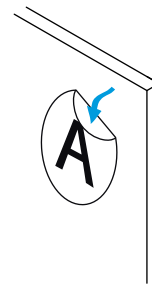
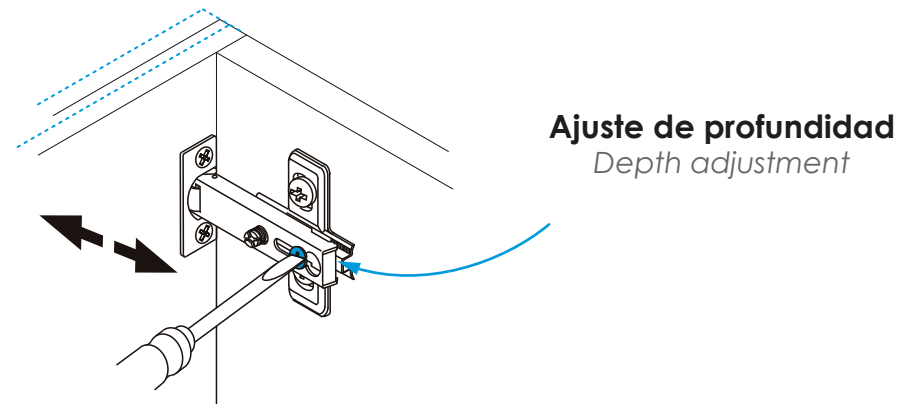

**Al terminar de armar desprenda los adhesivos (en caso de que queden residuos de pegante, limpie la superficie con alcohol).**

*When you finish assembling, remove the adhesives (in case there is glue residue, clean the surface with alcohol).*

 **Mueble armado completamente**  
Fully assembled cabinet

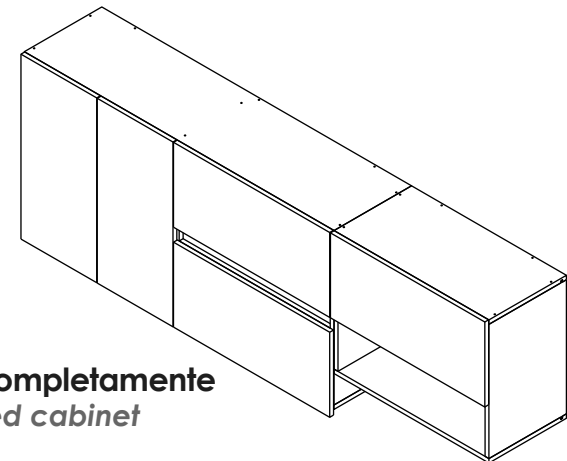



## Cuidados y mantenimiento

Care and maintenance

### Cuidados y mantenimiento para los muebles

- Para limpiar el mueble use un trapo seco o humedézcalo en agua y detergente suave, elimine el exceso de agua.
- No pinte ni barnice el mueble.
- No exponga el mueble a la intemperie.
- Evite arrastrarlo, puede ocasionar daños en la estructura.
- Por seguridad, evite que los menores jueguen con el mueble.
- No exponga el mueble a funciones diferentes para lo que fueron diseñados. Ejemplo: sentarse en el mueble.

### Care and maintenance for cabinet

- *To clean the cabinet, use a dry cloth or moisten it in water and mild detergent.*
- *Do not paint or varnish the furniture.*
- *Do not expose the furniture to the out side.*
- *Avoid dragging it, it can cause damage to the structure.*
- *For safety, avoid children playing with the furniture.*
- *Do not expose the furniture to different functions for which they were not designed. Example: sit on the furniture.*

### GARANTÍA

Para obtener más información sobre la garantía de los muebles, ingrese al enlace o escanee el código QR.

**Importante:** Consulte la garantía antes de hacer una reclamación.

### WARRANTY

*For more information on the furniture warranty, please enter the link or scan the QR code.*

**Important:** *Check the warranty before making a claim.*

### Código QR - Code Qr



**Si necesita ayuda comuníquese con su asesor comercial firplak**  
*if you need help, contact your business advisor firplak*



[www.firplak.com](http://www.firplak.com)

Sede principal: Calle 29 N° 41-15 (Itagüí - Antioquia), Teléfono: (574) 444 17 71