

Instrucciones de instalación

Installation Instructions

Mueble auxiliar básico piso para sanitario 60 x 21,5 cm Mueble para el baño

*Basic auxiliary cabinet for toilet 23.6" x 8.4"
bathroom sink cabinet*



¡Importante!

Important!

Antes de empezar a ensamblar el mueble, lea detenidamente las instrucciones. Pre-ensamble el mueble sobre su caja, para no rayarlos. Si falta una parte o piensa que esta defectuosa no devuelva el mueble al almacén; le agradecemos llamar al Firplak **tel: 4441771 (opción: 2)** o comuníquese con su asesor principal, también nos pueden escribir a **servicioalcliente@firplak.com** o al **Whatsapp +57 316-481-2857**

*Before starting to assemble the furniture, carefully read the instructions. Pre-assemble the furniture on its box to avoid scratching it. If a part is missing or you think it's defective, please do not return the furniture to the store. We appreciate you calling Firplak at **tel: 4441771 (option: 2)** or contacting your main advisor. You can also reach us by email at **servicioalcliente@firplak.com** or via **WhatsApp at +57 316-481-2857**.*



Recomendaciones previas

Previous recommendations



Si las paredes donde va a ubicar el mueble son en drywall, debe adquirir chazos y tornillos especiales para su instalación.

If the walls where you are locating the cabinet are in drywall, you must purchase special ramplug and screws for installation.



No golpee ni martille todo el mueble, sólo donde se le indica.

Do not strike or hammer all the cabinet, only where directed.



No pinte ni barnice el mueble.

Do not paint or varnish the cabinet.



No arrastre ni se suba al mueble, si necesita moverlo por favor levántelo.

Do not drag or stand on the cabinet, if you need to move it please lift up.



Lea detenidamente y siga en orden consecutivo las instrucciones de armado.

Read carefully and follow in sequence the assembly instructions.



No expongas el mueble a la intemperie, ni al calor.

Do not expose the cabinet to the outdoors or the heat.

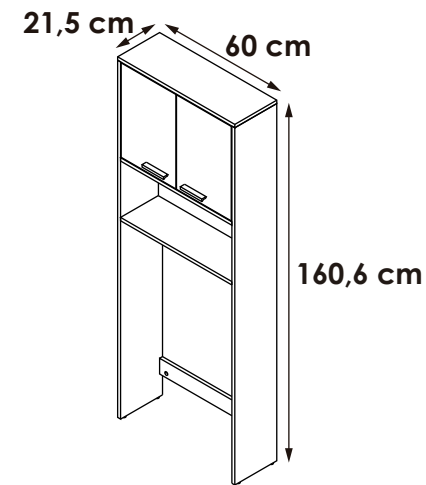

Sello de calidad / Quality seal

Por favor no deseche el instructivo del mueble, este le servirá para cualquier reclamo con respecto a la garantía del mismo.

Please do not discard the cabinet's instructions, it will serve you for any claim regarding its warranty.





Identificación de las partes Parts identification

Herramientas requeridas / Tools required

* No incluido.
Not included.



A Mueble para almacenamiento. Storage cabinet.



Tabla de piezas
Parts Chart

Pieza / Part	Cantidad / Total	Cantidad Total	Desde From	hasta to
A	1	11	A	K
B	1			
C	1			
D	1			
E	1			
F	1			
G	1			
H	1			
I	1			
J	1			
K	1			

B Identificación de herrajes Hardware identification

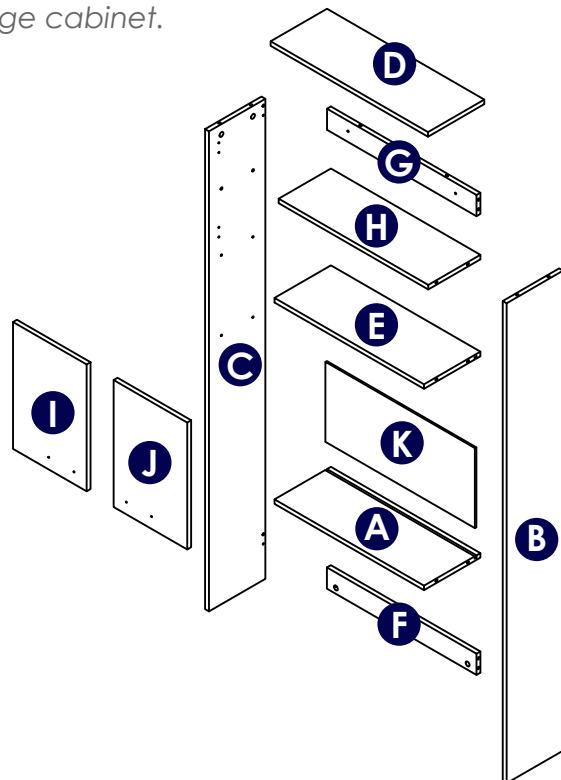

Chazos 2"
Ramplug 2"



Tornillos chazo 2"
Ramplug screws 2"



Pernos Minifix
Spreading bolt



Moneda Minifix
Minifix cams

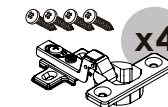

Bisagras internas
cierre lento
Internal hinges
slow closing



Tarugos
Wooden pins



Deslizadores
Sliders



Manija aluminio 96 mm
Aluminum Handle 96 mm



Tornillos para manija
Handle screws

* Tenga precaución al abrir la bolsa de herrajes de no perder ningún elemento. Compruebe si el contenido de las piezas es el correcto.
Be carefull opening the screw bag so you do not lose any. Chek if the number of screws is right.

C Recomendaciones de ensambles. Assembly recommendations

Instalación de minifix y pernos de minifix Installing the minifix cams and spreading minifix

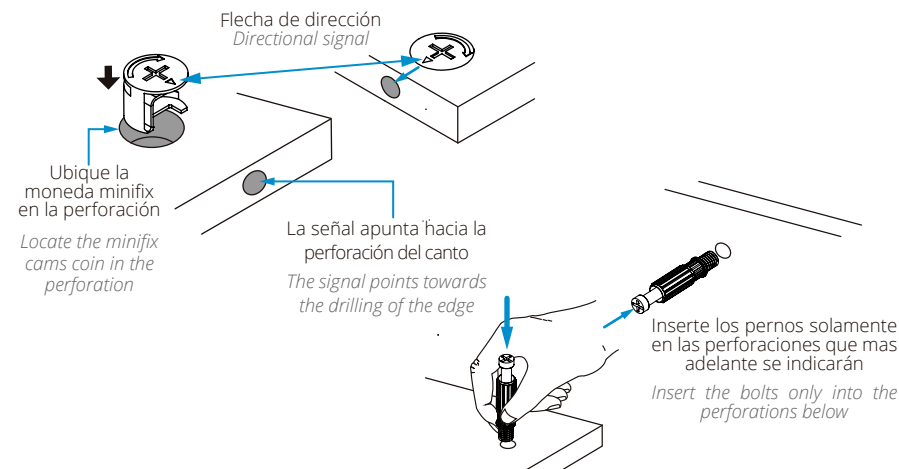

Ajustes de partes

Parts adjustments

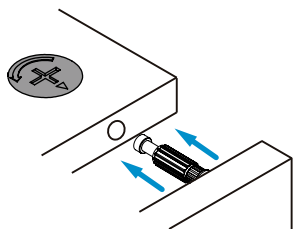

¿Cuánto debe girar una tuerca?
How much should a screw turn?

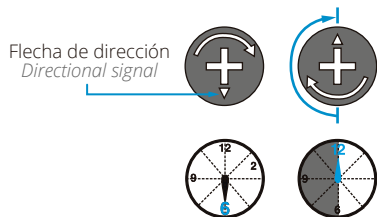

Tarugos

Wooden pins

Introduzca los tarugos solo hasta su tope máximo
Insert the wooden pins only up to their maximum peak

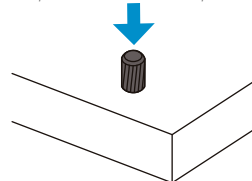

Inserte los tarugos solamente en las perforaciones que más adelante se indicarán
Insert the wooden pins only into the perforations below

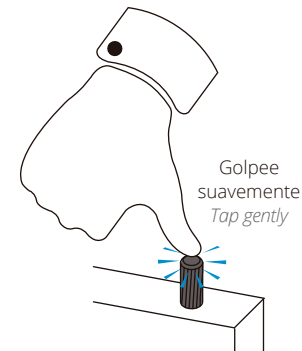
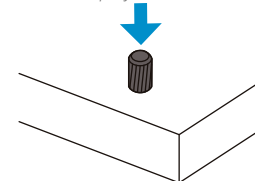

Preparación de las partes

Preparation of the parts

Se recomienda preparar las partes del mueble sobre la caja o una superficie lisa para no rayarlo.

It is recommended to prepare the parts of the cabinet on the box or on a flat surface to not scratch it.

Herramientas requeridas

Tools required



Herrajes

Fittings

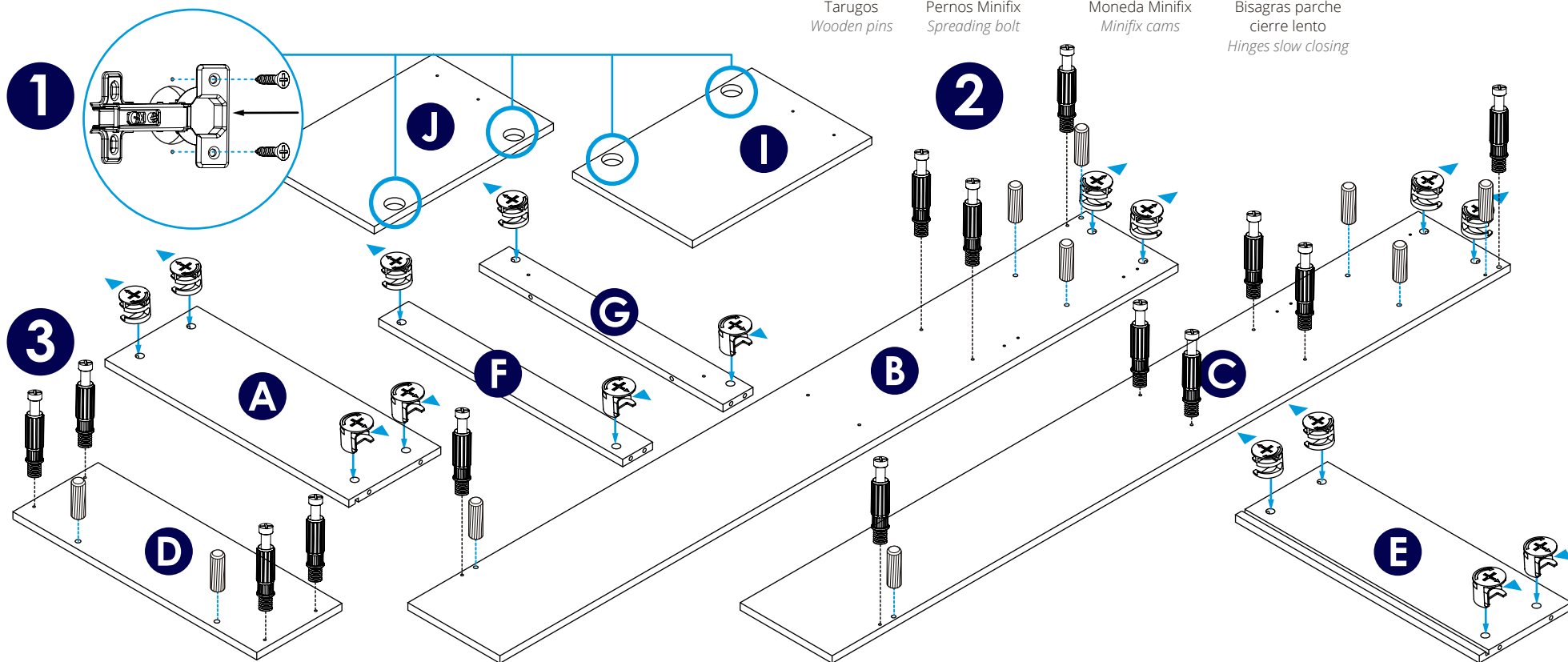



Ensamble de las partes

Assembly of the parts

✦ Se recomienda armar el mueble sobre la caja o una superficie lisa para no rayarlo.
It is recommended to assemble the product top of the box or on a flat surface to not scratch it.

Herramientas

Tools



Destornillador de estrella
Star screwdriver

Herrajes

Fittings



Tornillos ensamble 2"
Assembly screws 2"



Tornillos para manija
Handle screws



Tornillos chazo 2"
Ramp plug screws 2"



¡Importante!

Important!

- De un correcto armado de los muebles depende su buen funcionamiento.
- A medida que vaya encajando las piezas, ajuste con el destornillador.
- A proper assembly of the furniture guarantees the performance of the hinges.
- As the pieces fit together, adjust with the screwdriver.

1

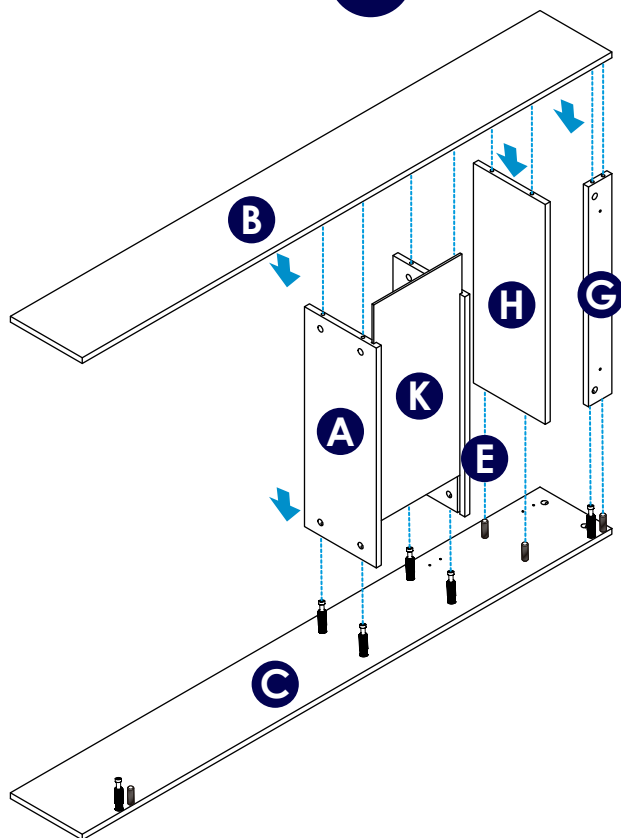

2

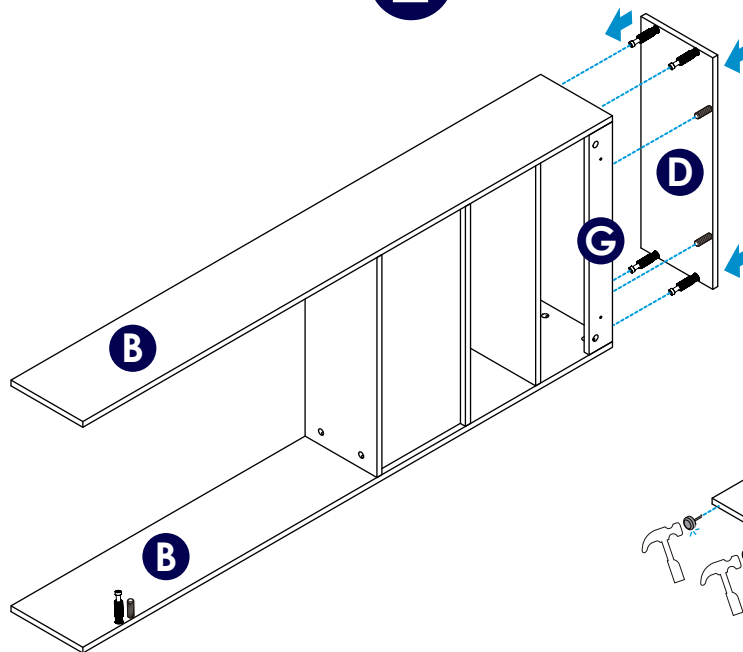

3

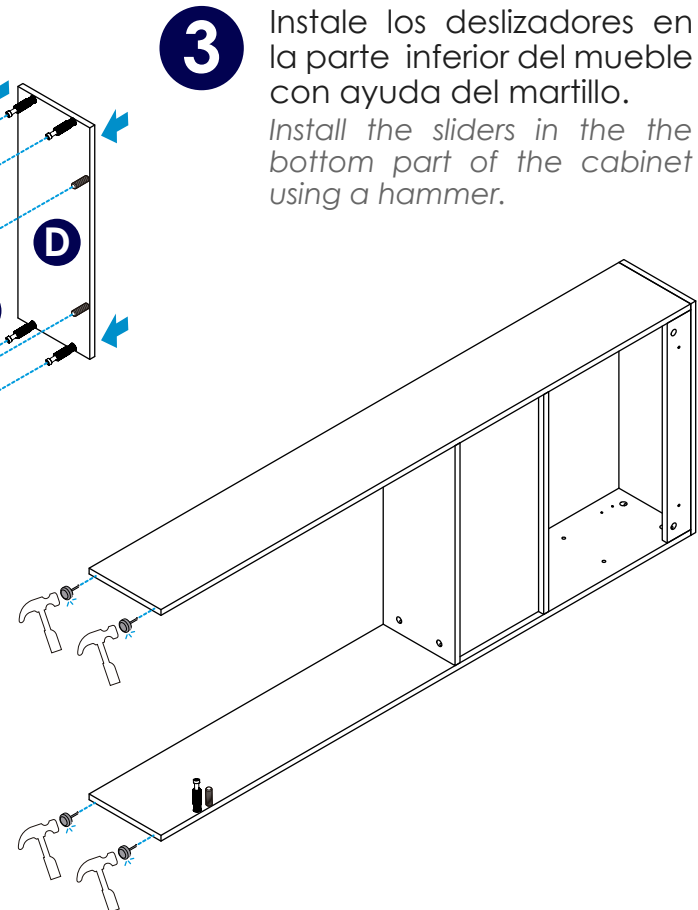

Instale los deslizadores en la parte inferior del mueble con ayuda del martillo.
Install the sliders in the the bottom part of the cabinet using a hammer.

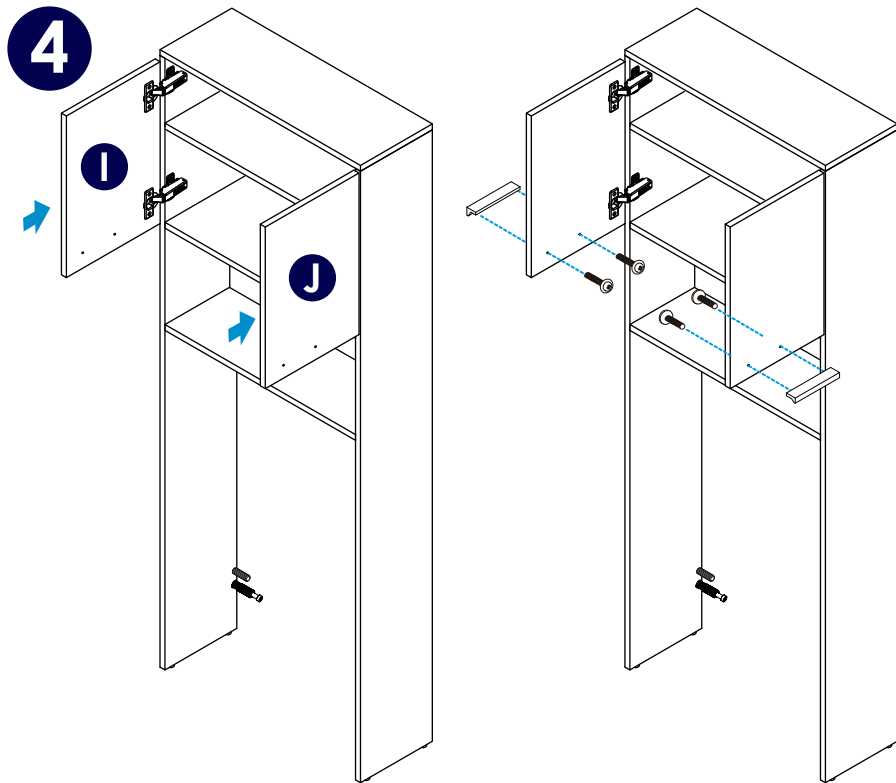

5 Ubique el mueble detrás del sanitario, cuando ya lo tenga en la posición adecuada proceda a poner el refuerzo trasero inferior como lo muestra la siguiente imagen.

Place the cabinet behind the toilet. Once it is in the correct position, proceed to install the lower rear brace as shown in the following image.

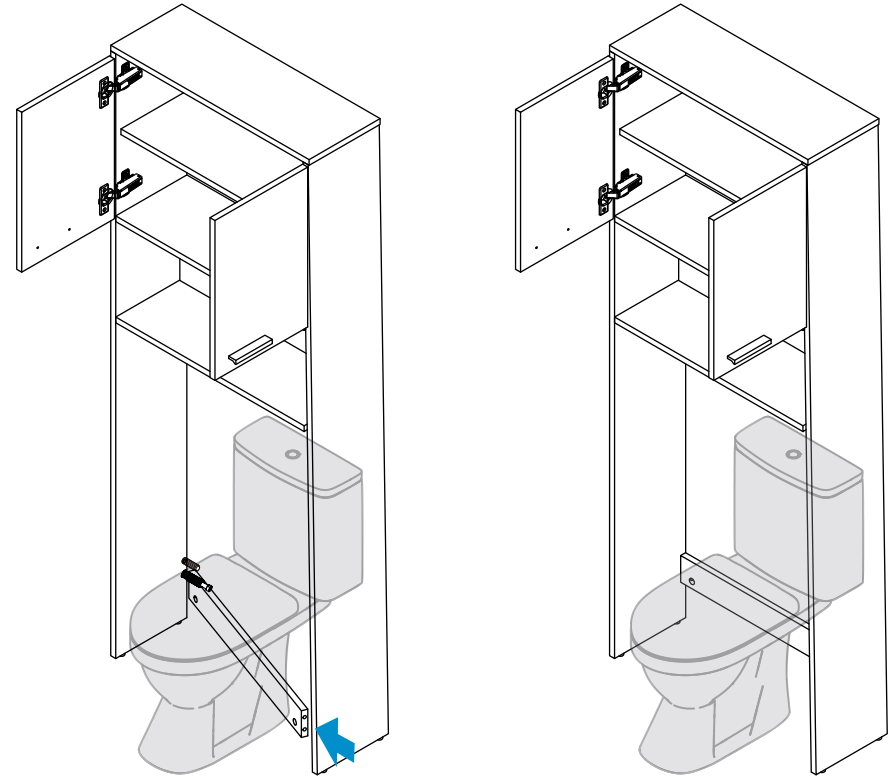

6 **Para fijar el mueble**
To secure the cabinet

Perfore la pared a la altura indicada de las perforaciones con ayuda de una broca para pared (tungsteno) 3/8", después introduzca el chazo plástico y asegure el mueble con tornillos chazos.

Drill the wall at the indicated height of the perforations with the help of a 3/8" wall bit (tungsten), then insert the plastic slab and secure the furniture with screws.

Herramientas requeridas
Tools required



Herrajes
Fittings



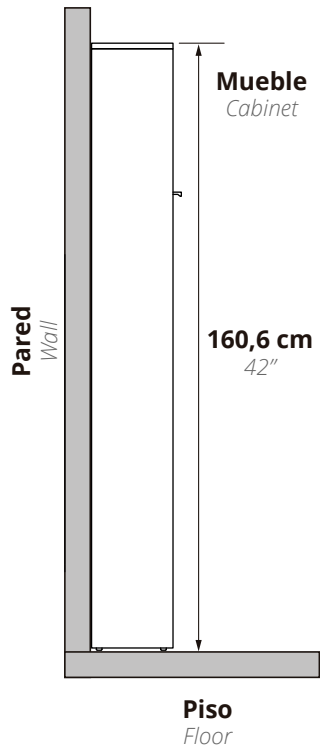

Tenga en cuenta que las paredes deben ser sólidas, de cemento / ladrillo. Si va a instalar el mueble sobre paredes de Drywall (paredes secas), debe utilizar chazos y tornillo de expansión metálico especial para drywall.

Note that the walls must be solid, cement / brick. In case of drywall installation, change the ramplug for a drywall metallic Spring Toggle.

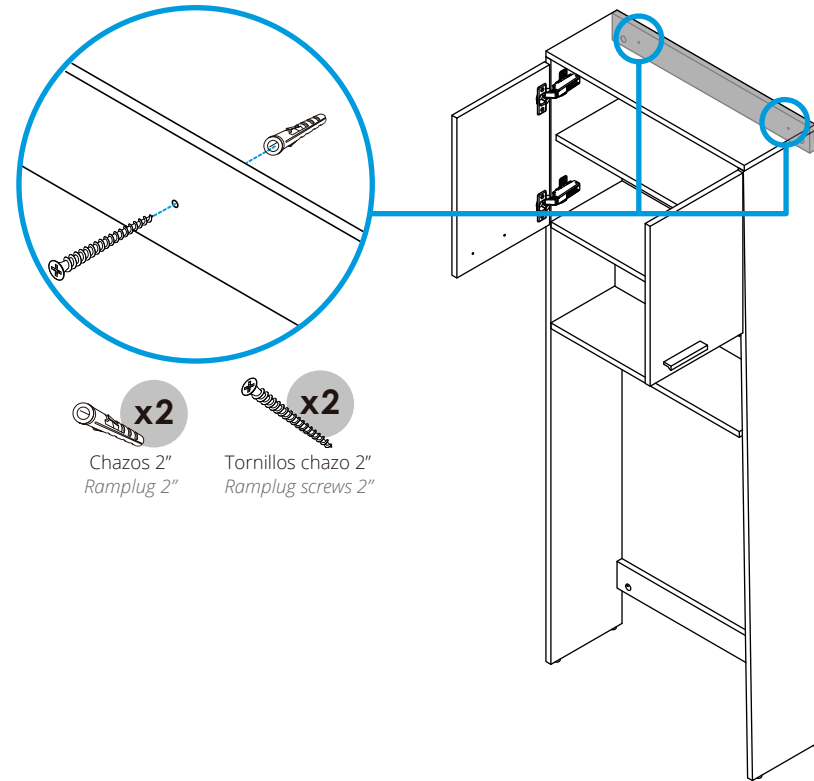

*** Mueble armado completamente**
Fully assembled cabinet

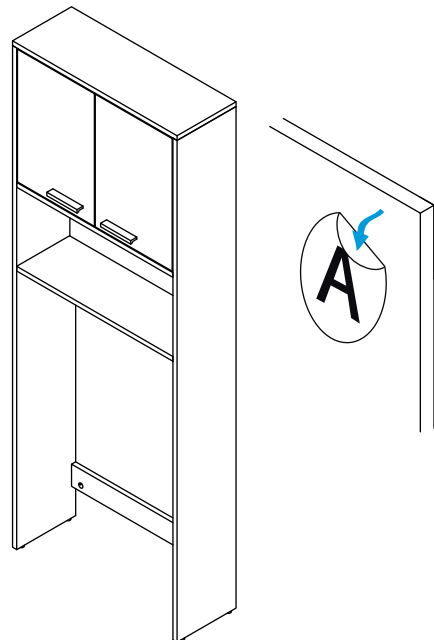

- Al terminar de armar desprenda los adhesivos (en caso de que queden residuos de pegante, limpie la superficie con alcohol).
- Recuerde ajustar las dos monedas internas de los minifix para completar el armado del mueble.
- When you finish assembling, remove the adhesives (in case there is glue residue, clean the surface with alcohol).
- Remember to adjust the two internal coins of the minifix cams to complete the assembly of the cabinet.



Cuidados y mantenimiento

Care and maintenance

Cuidados y mantenimiento para los muebles

- Para limpiar el mueble use un trapo seco o humedézcalo en agua y detergente suave, elimine el exceso de agua.
- No pinte ni barnice el mueble.
- No exponga el mueble a la intemperie.
- Evite arrastrarlo, puede ocasionar daños en la estructura.
- Por seguridad, evite que los menores jueguen con el mueble.
- No exponga el mueble a funciones diferentes para lo que fueron diseñados. Ejemplo: sentarse en el mueble.

GARANTÍA

Para obtener más información sobre la garantía de los muebles, ingrese al enlace o escanee el código QR.

Importante: Consulte la garantía antes de hacer una reclamación.

WARRANTY

For more information on the furniture warranty, please enter the link or scan the QR code.

Important: Check the warranty before making a claim.

Código QR - Code Qr



Care and maintenance for cabinet

- To clean the cabinet, use a dry cloth or moisten it in water and mild detergent.
- Do not paint or varnish the furniture.
- Do not expose the furniture to the outside.
- Avoid dragging it, it can cause damage to the structure.
- For safety, avoid children playing with the furniture.
- Do not expose the furniture to different functions for which they were not designed. Example: sit on the furniture.

Si necesita ayuda comuníquese con su asesor **comercial firplak**
if you need help, contact your **business advisor firplak**



www.firplak.com

Sede principal: Calle 29 N° 41-15 (Itagüí - Antioquia), Teléfono: (574) 444 17 71